



# TOOLS

· CATALOGUE No. 57

WODEN TOOLS LTD  
WODEN WORKS · WEDNESBURY · ENGLAND





# ENGINEERS AND JOINERS TOOLS

*Telephones:*

HEAD OFFICE & WORKS: JAMES BRIDGE 3166 (EIGHT LINES)

LONDON OFFICE: MANSION HOUSE 9016

*Telegrams:*

"WODEN WEDNESBURY"

"NUTSAMPTO CANNON LONDON"

*Codes:*

A B C      M A R C O N I

5TH EDITION INTERNATIONAL

## WODEN TOOLS LTD

WODEN WORKS • WEDNESBURY • ENGLAND



# INDEX

## ALPHABETICAL NAME INDEX

Name	Page
Bench Holdfasts	23
Bench Planes	5, 7, 8
Bench Screw	24
Bench Stop	23
Block Planes	9
Cramps, Flooring	19-22
"    Corner	25
"    'G'	17-18
"    Heads	24
"    Sash	10, 11, 14, 15
"    'T' Bar	12-15
"    Quick-Action	16
Combination Vice	35
Fibre Jaws for Vices	52
Fillister Plane	6
Floor Vice	50
Jack Planes	7
Jacks, Lifting	55-57
Jaw Plates for Vices	51
Lathe Carriers	54
Planes, Bench	5, 7, 8
"    Block	9
"    Fillister	6
"    Jack	7
"    Smooth	7
"    Fore	8
"    Jointer	8
Portable Vice Stands	36, 37, 53
Smooth Planes	7
Swivel Bases for Vices	39, 41, 43, 45, 47, 48
Table Vices	30, 48
Tube Vices	32-37
Vices, Bench	38-47
"    Combination	35

(continued)

## NUMBER INDEX

Catalogue No.	Page
W4	7
W4C	7
W4 $\frac{1}{2}$	7
W4 $\frac{1}{2}$ C	7
W5	7
W5C	7
W5 $\frac{1}{2}$	7
W5 $\frac{1}{2}$ C	7
W6	8
W6C	8
W7	8
W7C	8
W78	6
95	49
100/2	50
104	10
105	11
W110	9
112	12
113	13
114	15
115	15
116	15
126	17
W130	9
131	18
133	16
138	20-21
140	19
142	22
143	22
151	24
179	35
180	32
182	34
182A	34
183	34

(continued)



# INDEX

(continued)

## ALPHABETICAL NAME

INDEX (continued)

Name	Page
Vices, Floor	50
„ Instantaneous	42-45
„ Machine	49
„ Saw Sharpening	23
„ Woodworkers	26-30
„ Jaws Fibre...	52
„ Jaw Plates	51
„ Swivel Bases	48
„ with Swivel Base	39, 41, 43, 45, 47
„ Table	30, 48
„ Titan	48
„ Tube	32-37
„ Stands Display	5, 58-60
„ Stands Portable	36, 37, 53
„ Viking Hinged Tube	33

## NUMBER INDEX

(continued)

Catalogue No.	Page
186B	38-39
186E	42-43
186 S	40-41
187A	23
189	26
189A	28
189B	27
190	44-45
190A	46-47
191	54
192	29
194	30
194A	30
195	53
196	53
197A	36
197B	37
201	33
215	23
221A	23
229, 229A	57
233	24
239A	55
240, 240A	56
X251	49
X260	48
C800	25
C801	25
Fibre Jaws	52
Swivel Bases...	48
Vice Jaw Plates	51

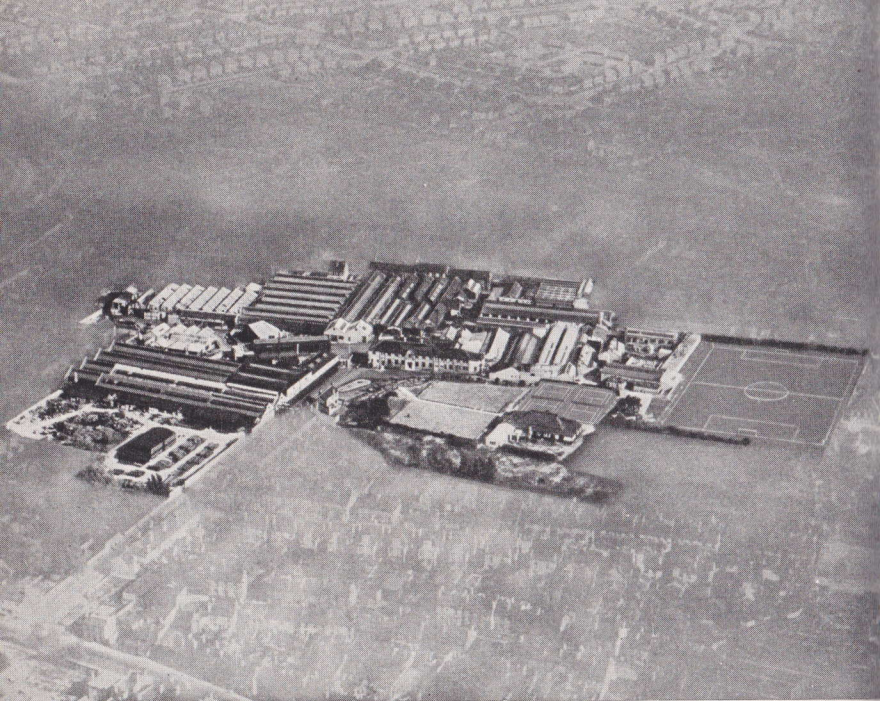

# WODEN WORKS

## *Introduction*

The very latest methods of manufacture, supported by 100 years of experience, have made it possible for us to offer Woden Tools superior even to those upon which our world-renowned reputation has been built in the past.

The Tools illustrated in this Catalogue are manufactured in our own factory which includes a Foundry, Steel Works and Laboratory, all of which ensure that the material, workmanship and finish leave nothing to be desired.

It is our policy to offer quality Tools for the Craftsman and any constructive suggestions are always welcome.



# WODEN PLANES

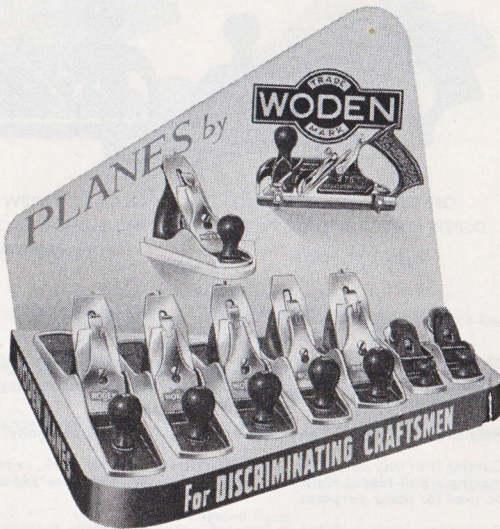

This attractive Display Unit, constructed in timber and Plywood, cellulosed in four colours is designed to display a range of nine Woden Planes.

It is supplied free of charge to approved stockists, the Planes only being invoiced at normal prices.

It should be ordered under the reference W.P.9.

---

WODEN TOOLS LTD. : WODEN WORKS : WEDNESBURY : ENGLAND

---



No. W78

## W O D E N F I L L I S T E R P L A N E

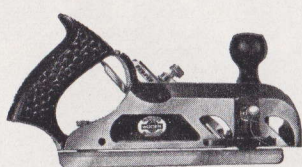

OFF-SIDE VIEW SHOWING  
DEPTH GAUGE & DISC INCISING  
CUTTER

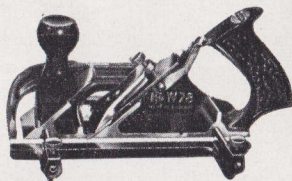

NEAR-SIDE VIEW SHOWING  
TWO SUPPORTING RAILS AND  
FULL LENGTH FENCE

This is a multi-purpose tool, incorporating the following outstanding features :  
Adjustable fence is held rigidly in position by two supporting rails, which are readily removable.

Rails and fence may also be fitted to the off-side of the plane body.

Cutting iron may be used in central position for normal work, or in forward position making a Bull-Nosed Plane, and by also removing the fence and rails the Plane can be used for many purposes.

A wooden knob is fitted in forward position of plane for providing a firm and comfortable grip when cutting iron is in normal position.

An adjustable and substantial depth gauge, and hardened steel disc incising cutter are fitted to off-side of plane body.

PRECISION GROUND FINISH on all faces of Body, ensure perfect squareness and smooth operation.

All Bright Parts, and Screws, with the exception of the cutting iron, are heavily chromium plated and polished, thereby maintaining a high quality finish throughout the life of the plane.

---

WODEN TOOLS LTD. : WODEN WORKS : WEDNESBURY : ENGLAND

---





# W O D E N   B E N C H   P L A N E S

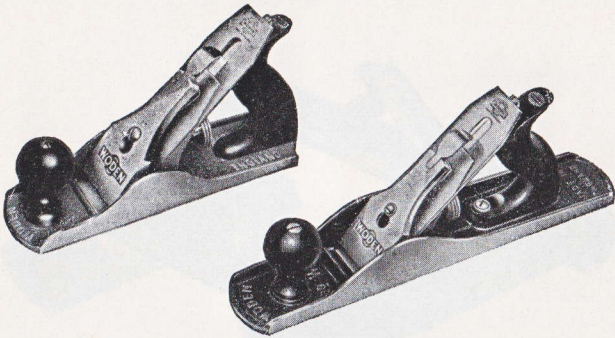

## SMOOTH PLANES

No. W4		
Length 9"	Cutter 2"	Weight 3½ lbs.
No. W4C		
Length 9"	Cutter 2"	Weight 3½ lbs.
No. W4½		
Length 10"	Cutter 2½"	Weight 5 lbs.
No. W4½C		
Length 10"	Cutter 2½"	Weight 5 lbs.

## JACK PLANES

No. W5		
Length 14"	Cutter 2"	Weight 5 lbs.
No. W5C		
Length 14"	Cutter 2"	Weight 5 lbs.
No. W5½		
Length 15"	Cutter 2½"	Weight 6 lbs.
No. W5½C		
Length 15"	Cutter 2½"	Weight 6 lbs.

C Denotes Corrugated Bases.

The Body, Frog and Lever Cap are made from the finest quality grey iron castings. Both the SIDES and the BASE are PRECISION GROUND and are absolutely square one to another.

Cutters are made from the finest Sheffield CRUCIBLE CAST STEEL, hardened and specially tempered. Each Cutter is precision ground and individually tested for correct hardness.

The Lever Cap and Lateral adjusting lever are CHROMIUM PLATED.

These Planes are made to the highest standards of British Engineering.

---

WODEN TOOLS LTD. : WODEN WORKS : WEDNESBURY : ENGLAND

---



## W O D E N   B E N C H   P L A N E S

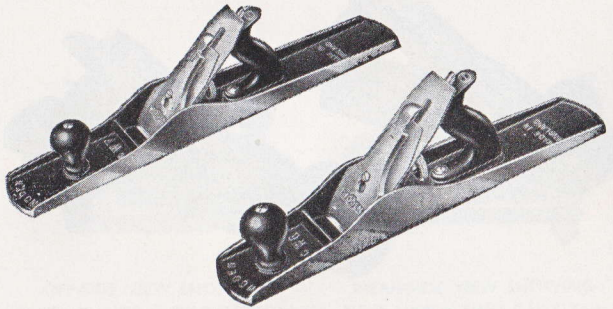

### WODEN FORE AND JOINTER PLANES

No. W6

No. W7

Length 18" Cutter  $2\frac{3}{8}$ " Weight 8 lbs.    Length 22" Cutter  $2\frac{3}{8}$ " Weight 8 lbs. 12 ozs.

No. W6C

No. W7C

Length 18" Cutter  $2\frac{3}{8}$ " Weight 8 lbs.    Length 22" Cutter  $2\frac{3}{8}$ " Weight 8 lbs. 12 ozs

C—Denotes Corrugated Bases.

The Body, Frog and Lever Cap are made from the finest quality grey iron castings. Both the SIDES and the BASE are PRECISION GROUND and are absolutely square one to another.

Cutters are made from the finest Sheffield CRUCIBLE CAST STEEL, hardened and specially tempered. Each Cutter is precision ground and individually tested for correct hardness.

The Lever Cap and Lateral adjusting lever are CHROMIUM PLATED.

These Planes are made to the highest standards of British Engineering.

---

WODEN TOOLS LTD. : WODEN WORKS : WEDNESBURY : ENGLAND

---



# W O D E N   B L O C K   P L A N E S

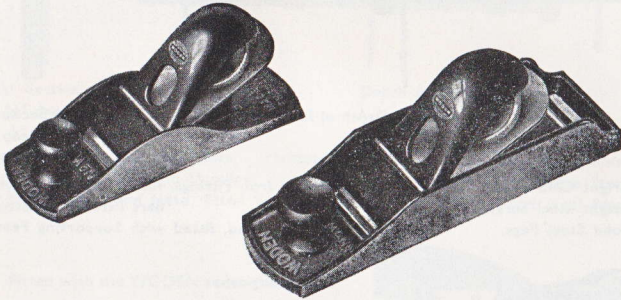

NON-ADJUSTABLE

No. W110

Length 7" Cutter 1 1/8" Weight 1 1/2 lbs.

DOUBLE ENDED NON-ADJUSTABLE

No. W130

Length 8" Cutter 1 1/8" Weight 1 3/4 lbs.

These Planes are very useful for all the many jobs that do not require a frequent adjustment of the Plane. They are made to the same high standard both as regards accuracy and finish as those illustrated opposite and are first class tools for either the craftsman or amateur.

The No. W130 has two mouths and two cutter seats. The illustration shows the cutter in the usual position, but the Lever Cap and Cutter may be reversed to form a BULL-NOSE PLANE.



No. 104

# WODEN STEEL SASH CRAMP

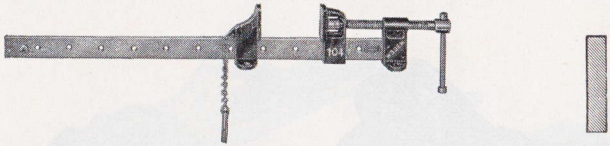

Depth of Jaws 2 inches.

Bar Section  
1½" deep  
¼" wide

Bright Cold Drawn Steel Bars. Malleable Iron Fittings, finished Woden Blue.  
Bright Steel Screws and Handles. Bars fitted with Stop.  
Solid Steel Pegs. Adjusting Jaws and Head, fitted with Supporting Feet.

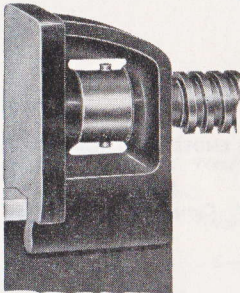

Fitted with the WODEN redesigned and improved working slide.

Reinforced H Section gives greater strength.

The end of the screw bears against the inner face of the cap. Thrust is distributed over a larger working area giving great pressure and long life.

When ordering Cramps, State LENGTH OF BAR, not size Cramps take in.

Length of Bar	....	24	30	36	42	48 inches
To take in	....	18	24	30	36	42 ..
Weight	....	4½	5½	5½	6½	6½ lbs.

WODEN TOOLS LTD. : WODEN WORKS : WEDNESBURY : ENGLAND



No. 105

# WODEN STEEL SASH CRAMP



Bar Section  
 $1\frac{1}{2}$ " deep  
 $\frac{3}{8}$ " wide

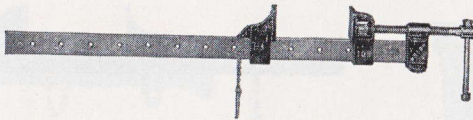

Depth of Jaws  $2\frac{1}{2}$  inches.

Bright Cold Drawn Steel Bars. Malleable Iron Fittings, finished Woden Blue.  
 Bright Steel Screws and Handles. Bars fitted with Stop.  
 Adjusting Jaws and Head, fitted with Supporting Feet. Solid Steel Pegs.

Fitted with the WODEN redesigned and improved working slide.

Reinforced H Section gives greater strength.

The end of the screw bears against the inner face of the cap. Thrust is distributed over a larger working area giving great pressure and long life.

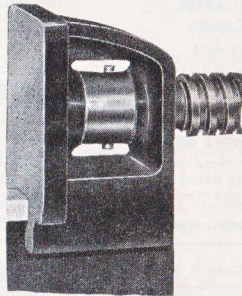

When ordering Cramps state LENGTH OF BAR, not size Cramps take in

Length of Bar ...	24	30	36	42	48	54	60 inches
To take in ....	18	24	30	36	42	48	54 ..
Weight ... ..	6	7	8	9	10	11 $\frac{1}{2}$	12 lbs.

WODEN TOOLS LTD. : WODEN WORKS : WEDNESBURY : ENGLAND



No. 112

# WODEN STEEL T-BAR CRAMP

HEAVY PATTERN



Bar Section  
 $2\frac{3}{8}$ " deep  
 $\frac{7}{8}$ " wide

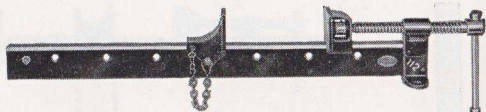

Depth of Jaws  $2\frac{1}{2}$  inches.  
 Diam. of Screw  $\frac{7}{8}$  inch.



These Bar Cramps are made from special Cold Drawn High Tensile Steel, and will not spring or bend in use.

The top edges, or T, on which the Slides work, are accurately machined and polished bright to ensure free action.

The Head and Slides are best malleable iron with polished bright edges, the Head being fitted with a supporting foot. Fitted with the WODEN redesigned and improved working slide as illustrated on page 10.

When ordering Cramps, state LENGTH OF BAR, not size Cramps take in.

Length of Bar ....	36	42	48	54	60 inches
To take in ....	30	36	42	48	54 "
Weight ....	17	$18\frac{1}{2}$	20	$21\frac{1}{2}$	23 lbs.
Lengthening Bar :—					
Weight ....	$11\frac{1}{2}$	13	$14\frac{1}{2}$	16	$17\frac{1}{2}$ lbs.
Length of Bar ...	66	72	78	84	96 inches
To take in	60	66	72	78	90 "
Weight ....	$24\frac{1}{2}$	26	$27\frac{1}{2}$	29	32 lbs.
Lengthening Bar :—					
Weight ....	19	$20\frac{1}{2}$	—	—	— lbs.

WODEN TOOLS LTD. : WODEN WORKS : WEDNESBURY : ENGLAND



No. 113

# WODEN STEEL T-BAR CRAMP

LIGHT PATTERN

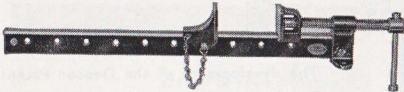

Depth of Jaws 2 inches.  
Diam. of Screw  $\frac{3}{4}$  inch.

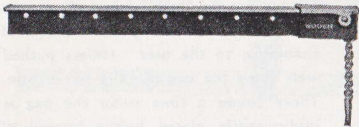

Bar Section  
 $1\frac{3}{4}$ " deep  
 $\frac{3}{8}$ " wide

These Bar Cramps are made from special Cold Drawn High Tensile Steel, and will not spring or bend in use.

The top edges, or T, on which the Slides work, are accurately machined and polished bright to ensure free action.

The Head and Slides are best Malleable Iron with polished bright edges, the Head being fitted with a supporting foot. Fitted with the WODEN redesigned and improved working slide as illustrated on page 10.

When ordering Cramps, state LENGTH OF BAR, not size Cramps take in.

Length of Bar	24	30	36	42	48	54	60	66	72 ins.
To take in	18	24	30	36	42	48	54	60	66 ..
Weight .....	7	8	9	10	11	12	13	14	15 lbs.
Lengthening Bar :— Weight	$5\frac{1}{2}$	$6\frac{1}{2}$	$7\frac{1}{2}$	$8\frac{1}{2}$	$9\frac{1}{2}$	—	—	—	— lbs.

WODEN TOOLS LTD. : WODEN WORKS : WEDNESBURY : ENGLAND



## THE DEACON PATENT TAIL SLIDE

PATENT No. 736120

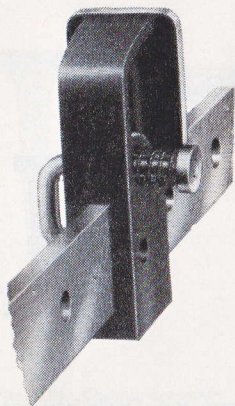

Fitted to  
No. 114    No. 115

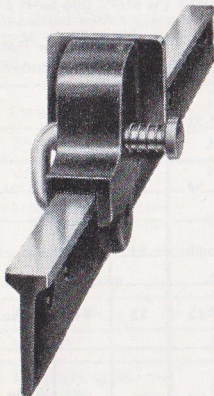

Fitted to No. 116

The development of the Deacon Patent Tail Slide represents a marked improvement in the traditional arrangement of fittings to Sash and T-Bar Cramps.

The old peg and chain method of securing the tail slide has for long been a source of annoyance to the user. Unless pushed well home the peg can slip out in use. There comes a time when the peg is inadvertently placed before instead of behind the slide; the chain breaks under pressure; the peg is subsequently lost and the user must resort to a makeshift with a screw or nail.

The Deacon Tail Slide operates by means of a spring-loaded catch. Depress this catch with the thumb and the slide may be freely moved along the bar, the pin automatically selecting the next stop. The tail slide is always securely held. Adjustment is automatic and simple.

The three patterns illustrated on the opposite page are standard bar cramps fitted with the Deacon Patent and are offered at a small increase in price above their old-style peg and chain equivalents.





# WODEN BAR CRAMPS

FITTED WITH THE DEACON PATENT TAIL SLIDE

## No. 114 STEEL SASH CRAMP

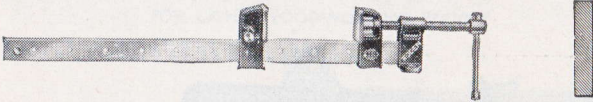

Depth of Jaws 2 inches.

Bar Section  
1½" deep  
¾" wide]

Detailed specification including Take in sizes and weights as for No. 104, see Page 10.

## No. 115 STEEL SASH CRAMP

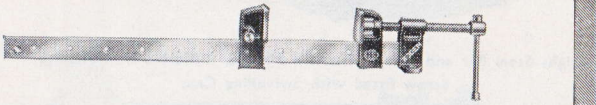

Depth of Jaws 2½ inches.

Bar Section  
1½" deep  
⅞" wide

Detailed specification including Take in sizes and weights as for No. 105, see Page 11.

## No. 116 STEEL T-BAR CRAMP

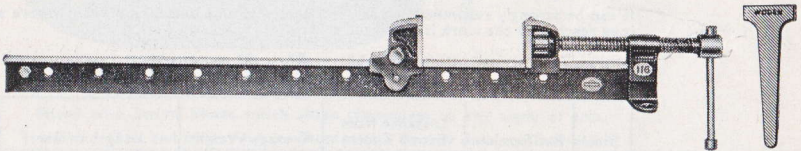

Depth of Jaws 2 inches.  
Screw Diam. ⅜ inch.

Bar Section  
1½" deep  
⅞" wide

Detailed specification including Take in sizes and weights as for No. 113, see Page 13

Tool No.	BAR LENGTHS									
	24	30	36	42	48 inches					
114 ... ..	24	30	36	42	48	54	60 inches			
115 ... ..	24	30	36	42	48	54	60	66	72 ins.	

WODEN TOOLS LTD. : WODEN WORKS : WEDNESBURY : ENGLAND



No. 133

## WODEN QUICK ACTION CRAMP

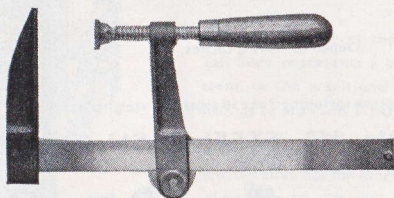

Bright Steel Bar and Screw, Wooden Handle, Malleable Iron Fittings.  
Screw fitted with Swivelling Cap.

In the shorter bar lengths this tool is a handy quick action 'G' Cramp for wood-working use.

In the longer bar lengths it serves as a quick action Sash Cramp.

It can be strongly recommended as a Veneering Cramp and for purposes where a long reach over the work is required.

Size No.	Bar Section	Distance from Bar to Centre of Screw	Average Weight	Length of Bar
3	1" $\times$ $\frac{1}{4}$ "	4"	2 $\frac{1}{2}$ lbs.	6", 8", 10"
5	1 $\frac{1}{4}$ " $\times$ $\frac{1}{4}$ "	5 $\frac{1}{2}$ "	4 $\frac{3}{4}$ lbs.	10", 12", 15", 18"
7	1 $\frac{1}{2}$ " $\times$ $\frac{5}{16}$ "	8"	8 $\frac{1}{4}$ lbs.	15", 18"

Longer bar lengths in each size may be ordered as required.

WODEN TOOLS LTD. : WODEN WORKS : WEDNESBURY : ENGLAND



No. 126

# WODEN RIBBED 'G' CRAMP

FOR LIGHT WOODWORKING SERVICE

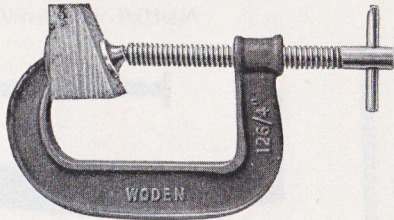

Sizes .... 2 3 4 5 6 8 inches

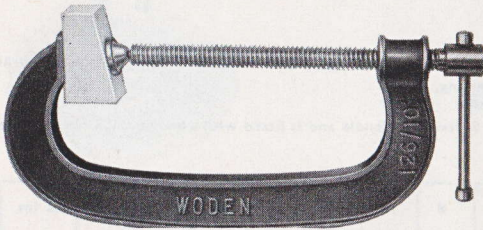

Sizes .... 10 12 14 inches

Malleable Iron Frames with Steel Screws and Handles.

Fitted with Swivel Shoes which adapt themselves to any angle of grip.

The 10 in., 12 in. and 14 in. sizes are fitted with a Tommy Bar (see illustration)

To take in	2	3	4	5	6	8	10	12 ins.	14 ins.
Height to centre of Screw	$1\frac{7}{8}$	$2\frac{1}{2}$	$2\frac{1}{2}$	3	$3\frac{1}{4}$	$3\frac{1}{2}$	4	$4\frac{5}{8}$ ,,	$5\frac{1}{8}$ ,,
Diameter of Screw	$\frac{1}{2}$	$\frac{1}{2}$	$\frac{9}{16}$	$\frac{5}{8}$	$\frac{5}{8}$	$\frac{3}{4}$	$\frac{3}{4}$	$\frac{3}{4}$ ,,	$\frac{7}{8}$ ,,
Approximate weight	14ozs.	$1\frac{1}{4}$	$1\frac{3}{4}$	$2\frac{3}{4}$	3	5	$6\frac{1}{2}$	8 lbs.	12 lbs.

WODEN TOOLS LTD. : WODEN WORKS : WEDNESBURY : ENGLAND



No. 131

## WODEN EXTRA STRONG 'G' CRAMP

ALL-STEEL, HEAVY DUTY

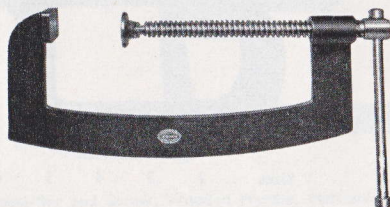

This is a Heavy-Duty Cramp suitable for Coachmakers, General and Agricultural Engineering and Welding, etc.

It has a steel Frame, Screw and Handle and is fitted with a Swivel Shoe for all-angle grip.

To take in	8	10	12	14	16	18	20	22 ins.
Height to centre of Screw	4½	4¾	5	5½	5½	5¾	6	6 ins.
Section	2 × ½	2 × ½	2½ × ½	2½ × ½	2½ × ⅝	2¾ × ⅝	3 × ¾	3 × ¾ ins.
Diameter of Screw	1	1	1½	1½	1½	1½	1⅞	1⅞ ins.
Weight	11	11¾	15	18½	23	25½	34	41 lbs.

WODEN TOOLS LTD. : WODEN WORKS : WEDNESBURY : ENGLAND



No. 140

# WODEN LEVER FLOORING CRAMP

WITH QUICK RELEASE

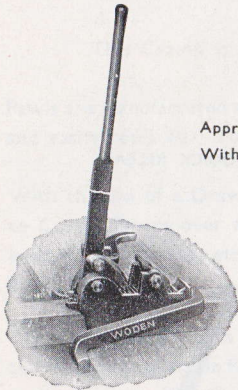

With Draw Bar

Approximate Weight	....	24½ lbs.
With Draw Bar	....	28 lbs.

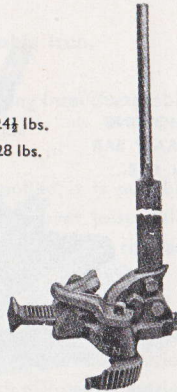

Without Draw Bar

(Supplied with or without Draw Bar.) Best Cast Iron Frame. Malleable Parts and Wrought Iron Lever.

With the aid of a Draw Bar as illustrated, it is possible to Cramp Floors over a flush surface, also Floors over Joists fully bedded in concrete, etc., and it is also useful for getting the last board up.

TO RELEASE pull back lever, press foot on tails of front pawls, and the Ram will be pulled back by the spring. Keep Ram well oiled underneath.

To suit Joists 1½ to 4 inches.

---

WODEN TOOLS LTD. : WODEN WORKS : WEDNESBURY : ENGLAND

---



No. 138

# WODEN FLOORING CRAMP

SHOWING  
DRAW BAR  
IN USE.

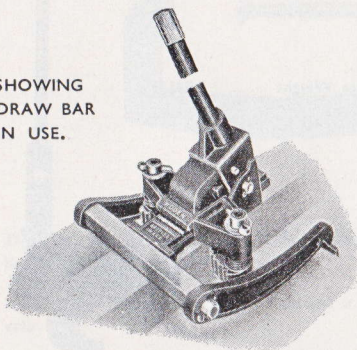

● QUICK RELEASE

SUPPLIED WITH OR  
WITHOUT DRAW BAR

To suit Joists 2 to 4 inches.

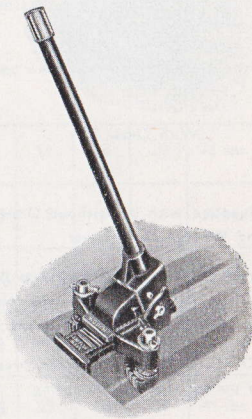

---

WODEN TOOLS LTD. : WODEN WORKS : WEDNESBURY : ENGLAND

---



No. 138

# WODEN FLOORING CRAMP

WITH QUICK RELEASE

This Cramp is made from Best Malleable Iron.

Pawls are manufactured of Mild Steel, all parts being interchangeable and easily replaced. To suit 2 in. to 4 in. Joists.

With the aid of a Draw Bar, which can be supplied, it is possible to Cramp Floors over a flush surface, also floors over joists fully bedded in concrete, etc., and it is also useful for getting the last board up.

**TO USE.**—The Lever is held right back, and the knob is depressed this action releases the Ram which immediately returns to a position ready for use. The Cramp is then pushed with a forward motion on to the Joist where the dogs will automatically grip. The Lever is then pulled forward and the boards will instantly begin to close up. The Lever can be actuated until the desired pressure is obtained.

**TO RELEASE.**—Pull the Lever forward and at the same time depress knob, which action releases the MILD STEEL pawls holding Ram in position. The Cramp will then leave the Joist freely.

Approximate weight, 16 lbs. ; or with Draw Bar 22 lbs.

---

WODEN TOOLS LTD. : WODEN WORKS : WEDNESBURY : ENGLAND

---



## WODEN FLOORING CRAMPS

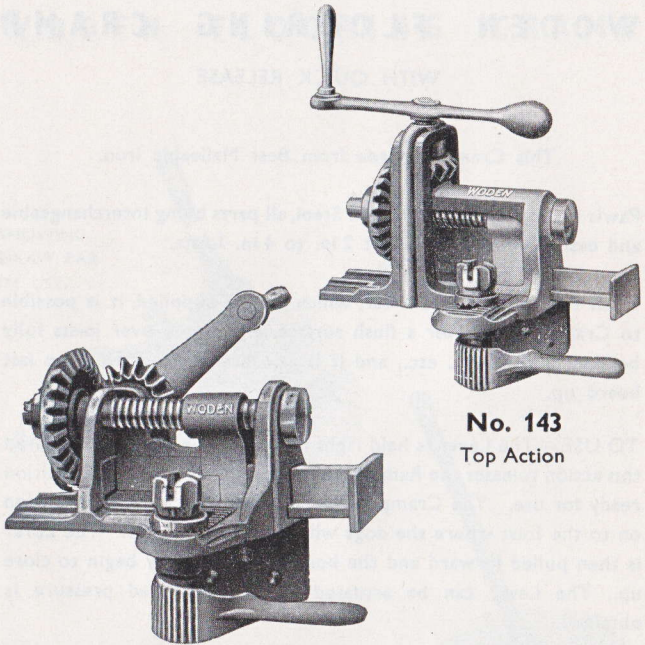

**No. 142**

Side Action

**No. 143**

Top Action

Malleable Iron Construction.

To suit joists ....  $1\frac{1}{2}$  to 6 inches

---

WODEN TOOLS LTD. : WODEN WORKS : WEDNESBURY : ENGLAND

---





# WODEN JOINERS' TOOLS

**No. 215. WODEN BENCH STOP**  
 Zinc Alloy Body. Steel Spring and Screw.  
 Weight, 6 oz.

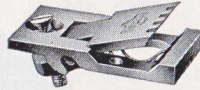

**No. 215**



**No. 187A**

**No. 187A. WODEN SAW SHARPENING VICE**  
 Best Cast Iron. With Malleable Iron Lever.  
 Jaws  $8\frac{1}{2}$  inches wide.  
 Will take Saws up to, and including 6 inches wide.  
 Weight, 5 lbs.

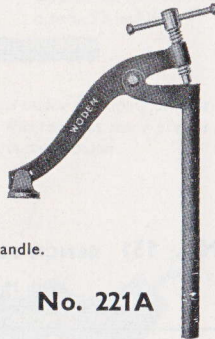

**No. 221A**

**No. 221A. WODEN BENCH HOLDFAST**  
 Malleable Iron Arm and Shoe. Steel Screw and Handle.

Size No. ....	0	1	2
Size of Pillar....	$10 \times \frac{3}{4}$	$12 \times \frac{7}{8}$	$14 \times 1$
Weight .....	$2\frac{1}{2}$	$4\frac{1}{2}$	6



## WODEN JOINERS' TOOLS

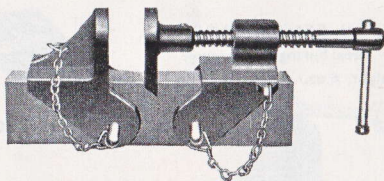

### No. 233 CRAMP HEAD

Best Cast Iron. Mild Steel Screw and Handle. To suit Planks 1 inch. Weight 2½ lbs.  
(Boxed)

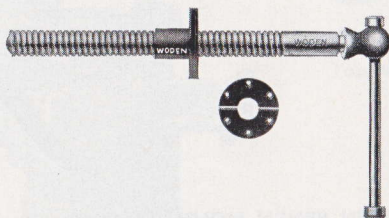

### No. 151 BENCH SCREW

With Malleable Split Collar and Nut.

Length	....	....	....	16	18	20 inches.
Diam. of Screw	....	....	....	1	1½	1½ "
Weight (approx.)	....	....	....	4½	8	9½ lbs.



# NEW CORNER CRAMPS

No. C801

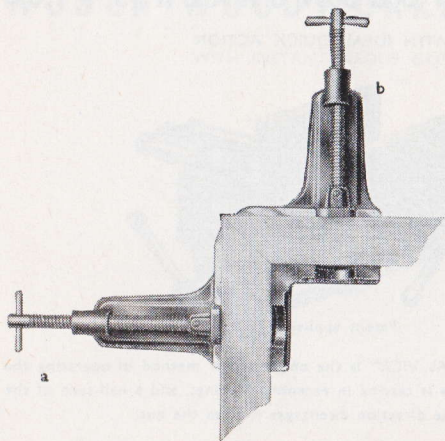

Of Solid Construction in best quality Grey Iron, finished in Woden Blue.

Working surfaces accurately machined.

Steel Screws and Handles

Furnished with two mounting holes for screwing to the bench.

Cramping capacity  $4\frac{1}{2}$  in.

Overall dimension from a to b, 13 inches.

Weight .... 6 lbs.

The open design makes it possible to nail and glue joints under Cramping pressure. In addition to its function as a mitre framing Cramp, this tool has many uses as a general purpose bench cramp and is a useful jig for the pattern maker.

## No. C800 Corner Cramp.

Constructed in best quality Grey Iron, finished in Woden Blue.

Furnished with two mounting holes for screwing to the bench.

Cramping capacity 2 in.

Overall Dimension a to b .... 8 in.

Weight .... 2 lbs

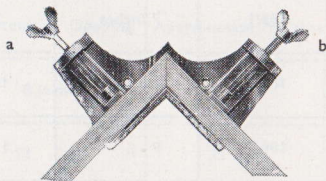



No. 189

## WODEN WOODWORKER'S VICE

WITH IDEAL QUICK ACTION

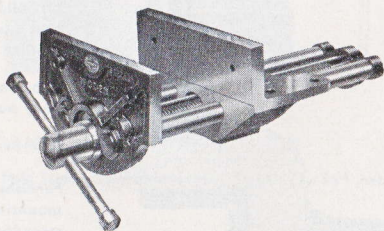

Patent applied for.

The feature of the "IDEAL VICE" is the entirely new method of operating the quick action. The screw is carried in eccentric bearings, and a half-turn of the handle in an anti-clockwise direction disengages it from the nut.

As there is no trigger in which fingers can be pinched this Vice is especially recommended for SCHOOLS and TECHNICAL COLLEGES, but Carpenters and Pattern-makers will also find the new action a great improvement.

Number	Width of Jaws	Extent of Opening	Approximate Weights
189/1	7 inches	8 inches	16 lbs.
189/1A	8 "	10 "	20 "
189/2	9 "	13 "	30 "
189/3	10½ "	15 "	33 "

WODEN TOOLS LTD. : WODEN WORKS : WEDNESBURY : ENGLAND



No. 189B

## WODEN WOODWORKER'S VICE

WITH INSTANTANEOUS GRIP

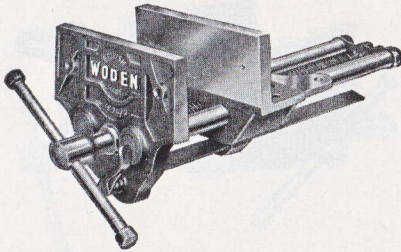

Whilst the "Ideal" Vice illustrated on the opposite page is a revolutionary advance in design, there is still a demand for the old quick action type illustrated above.

In both these models Bodies and Jaws are of best Cast Iron and they are fitted with detachable Malleable Iron Nuts and Polished Steel Slides.

Number	Width of Jaws	Extent of Opening	Approximate Weights
1	7 inches	8 inches	19 lbs.
2	9 "	13 "	35 "
3	10½ "	15 "	39 "

---

WODEN TOOLS LTD. : WODEN WORKS : WEDNESBURY : ENGLAND

---



No. 189A

# WODEN WOODWORKER'S VICE

PLAIN SCREW

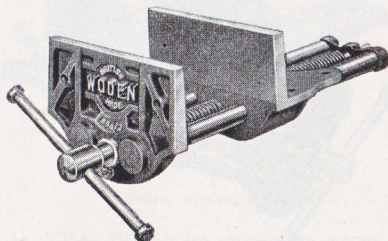

This model is similar in all respects to the 189B Vice illustrated on Page 27, except that it has no quick action. In place of this it is fitted with a plain screw operating in a solid detachable nut.

Number	Width of Jaws	Extent of Opening	Approximate Weights
1	7 inches	8 inches	18 lbs.
2	9 "	13 "	36 "
3	10½ "	15 "	38 "

WODEN TOOLS LTD. : WODEN WORKS : WEDNESBURY : ENGLAND



No. 192

## WODEN LIGHT WOODWORK VICE

RE-DESIGNED AND STRENGTHENED

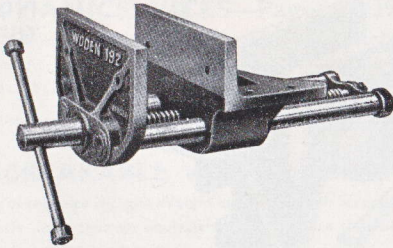

This Vice is of similar construction to the 189A Model illustrated on the opposite page, but is both cheaper and lighter as it is intended for less heavy work. It is in great demand by the home craftsman.

Width of Jaws : 7 inches.      Extent of Opening :  $6\frac{1}{2}$  inches.  
Approximate Weight :  $12\frac{1}{2}$  lbs.

PACKED IN A BOX

---

WODEN TOOLS LTD. : WODEN WORKS : WEDNESBURY : ENGLAND

---



## WODEN WOODWORKERS' VICES

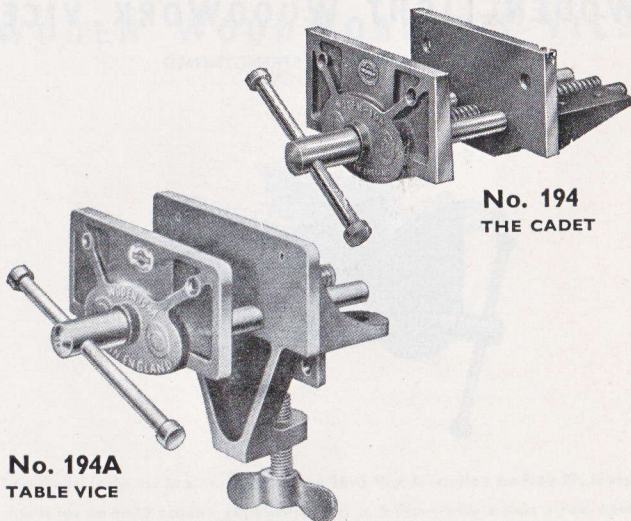

**No. 194**  
**THE CADET**

**No. 194A**  
**TABLE VICE**

### **No. 194—THE CADET**

A small, sturdy Vice, designed for the amateur craftsman. Easily fitted to bench. Steel Slides, Screw and Handle.

(NOTE : The SLIDES of this Vice are SCREWED into the front plate before being riveted.)

Width of Jaws : 6 in.

Opening :  $4\frac{1}{2}$  in.

Weight :  $6\frac{3}{4}$  lbs.

PACKED IN A BOX

### **No. 194A—TABLE VICE**

This Vice is similar to the "Cadet", with the addition of a Clamp to enable it to be more quickly fitted to a bench or table.

Will clamp on to boards  $\frac{3}{4}$ " to  $2\frac{1}{4}$ " thick.

Weight :  $9\frac{1}{4}$  lbs.

**SEE PAGE 48 FOR DETAILS OF THE WODEN TITAN.**  
**A MECHANIC'S VICE TO CLAMP ON A TABLE.**

---

**WODEN TOOLS LTD. : WODEN WORKS : WEDNESBURY : ENGLAND**

---





# ENGINEERS' SECTION

---

Detailed specifications of WODEN Fitters' and Mechanics' Bench Vices appear on pages 38 to 47.

The following notes may help buyers in selecting the most suitable Vice for their purpose.

## 186B MECHANICS' VICES—Pages 38/39

Strong and robust, the 186B in all sizes is recommended as the standard workshop Vice for industry. The smaller sizes are sold extensively by retailers to the householder. The 3", 3½" and 4" sizes are suitable for school metalwork rooms.

The 186B fills the demand for a strong bench Vice at a low price.

## 186S UNBREAKABLE VICE—Pages 40/41

The virtue of this vice is Light Weight combined with Strength and Durability. Costing little more than an equivalent cast iron vice the 186S will withstand rough treatment and hard usage.

It carries the Woden Guarantee of Unbreakability and in the No. 3-4" size provides the ideal Technical vice for school use.

## 186E FITTER'S VICE—Pages 42/43

The ideal Heavy Duty, Quick Release, Fitter's Vice for Industry, virtually unbreakable under all normal conditions of use.

The larger sizes are of massive construction and provide a heavy workshop vice at a low cost.

The Woden Workshops are equipped with 186E Vices.

## 190 and 190A UNBREAKABLE VICE—Pages 44/47

The 190 is a Heavy Duty, Quick Release, Fitter's Vice carrying the Woden Unbreakable Guarantee. It is practically indestructible and will meet the requirements of the most discriminating buyer.

The 190A is a plain screw version of the 190. It can be recommended to give trouble-free service in Foundries and Workshops where abrasive dust is abundant in the atmosphere.



No. 180

# W O D E N T U B E V I C E S

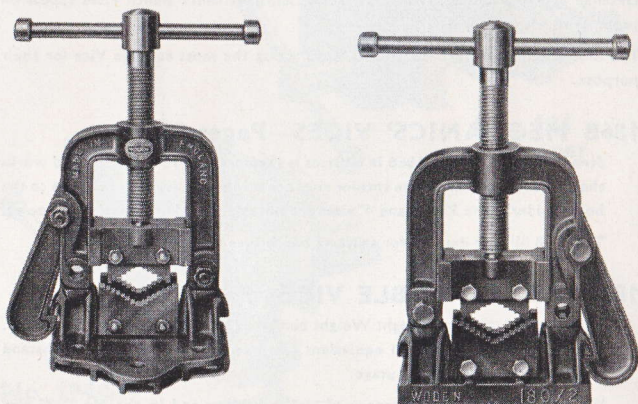

SELF-LOCKING HINGED TUBE VICE

Malleable Iron Frame with Steel Screw. Jaws are made from carefully hardened Tool Steel. The Frame is reversible so that the Vice can be used either right or left hand. All parts interchangeable.

Size No. ....	0	1	2	3	4	5
To grip Tubes ....	$\frac{1}{8}$ to 1"	$\frac{1}{8}$ to 1 $\frac{1}{2}$ "	$\frac{1}{8}$ to 2"	$\frac{1}{8}$ to 2 $\frac{1}{2}$ "	$\frac{1}{8}$ to 3 $\frac{1}{2}$ "	$\frac{1}{8}$ to 4 $\frac{1}{2}$ "
Weight (approx.) ....	3	5	9 $\frac{1}{2}$	12	20	31 $\frac{1}{2}$ lbs.

WODEN TOOLS LTD. : WODEN WORKS : WEDNESBURY : ENGLAND



## WODEN "VIKING" HINGED TUBE VICE

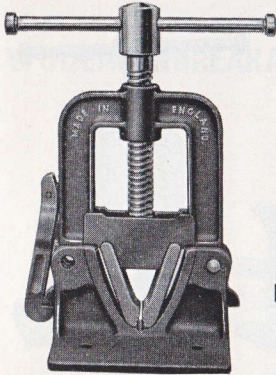

No. 201

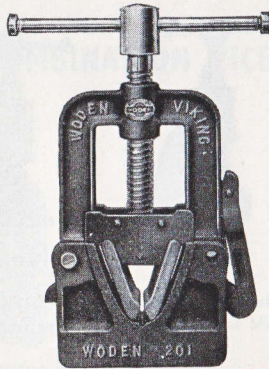

Malleable Iron Frame with Steel Screw and Handle. Jaws are made from carefully hardened Tool Steel. The Frame is reversible, enabling Vice to be used either right or left-hand. The massive construction of the WODEN "VIKING" VICE makes it pre-eminent for use by heating and electrical engineers. The design of the Jaws makes it possible to hold all kinds of irregular shapes without difficulty. The Jaws being much wider than ordinary Hinged Vices gives added gripping surface and will hold tubes rigidly without crushing. The "VIKING" VICE is more costly than other Tube Vices of the same capacity, but the increased STRENGTH and ADAPTABILITY will be found worth the extra expenditure.

The illustrations show a valve, an elbow, a piece of  $\frac{1}{2}$  in. and a piece of 2 in. tube, all held equally well.

No.	Size	Weight	Capacity
201	1	19 lbs.	$\frac{1}{2}$ in.—2 $\frac{1}{2}$ in.

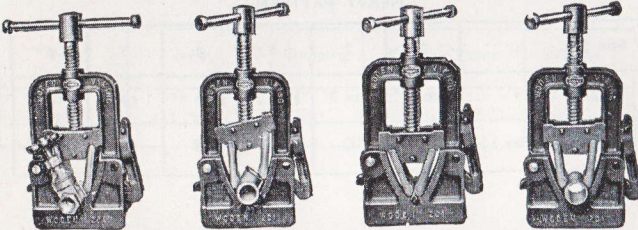

WODEN TOOLS LTD. : WODEN WORKS : WEDNESBURY : ENGLAND



# W O D E N T U B E V I C E S

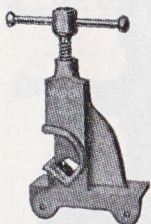

**No. 182**

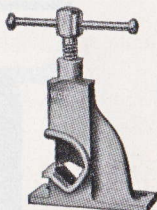

**No. 182A**

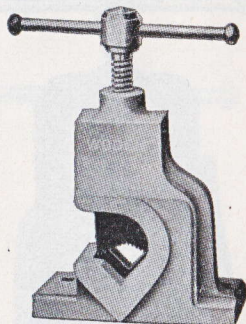

**No. 183**

**No. 182 and 182A** Malleable Iron Body.  
Mild Steel Screw and hardened Tool Steel Jaws.

### LIGHT PATTERN

Size No. ....	1	1A	2
To grip Tubes ....	$\frac{1}{8}$ to 1"	$\frac{1}{8}$ to 1 $\frac{1}{2}$ "	$\frac{1}{2}$ to 2"
Weight (approx.) :— No. 182 .... No. 182A ....	5 4 $\frac{1}{2}$	8 $\frac{1}{2}$ 8 $\frac{1}{2}$	16 lbs. 15 $\frac{1}{2}$ "

### No. 183

Cast Iron Body.

Mild Steel Screws and hardened Tool Steel Jaws.

### HEAVY PATTERN

Size No. ....	1	2	3	4	5	6
To grip Tubes ....	$\frac{1}{8}$ to 1 $\frac{1}{2}$ "	$\frac{1}{4}$ to 2"	$\frac{1}{2}$ to 3"	$\frac{1}{2}$ to 4"	1 to 5"	2 to 6"
Weight (approx.) :—	19	22	37 $\frac{1}{2}$	62	85	108 lbs.

WODEN TOOLS LTD. : WODEN WORKS : WEDNESBURY : ENGLAND



No. 179

## WODEN UNBREAKABLE COMBINATION VICE

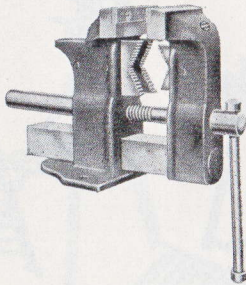

This Vice has the Jaws offset to enable large diameter pipes to be held in an upright position

The Jaws of the Tube Vice are of special quality hardened steel. The Back Jaw of the Tube Vice is fixed and set behind the Vice Jaw above it. The Front Tube Jaw is detachable. By removing the Front Jaw the full vertical depth from the parallel jaws to the screw is available when used as a mechanic's Vice.

No.	Jaws	Opening	To take Tubes	Weight
179	4 $\frac{1}{2}$ " Offset	4"	$\frac{1}{8}$ " to 2 $\frac{1}{2}$ "	24 lbs.

WODEN TOOLS LTD. : WODEN WORKS : WEDNESBURY : ENGLAND



No. 197A

**WODEN PORTABLE AND COLLAPSIBLE VICE STAND**

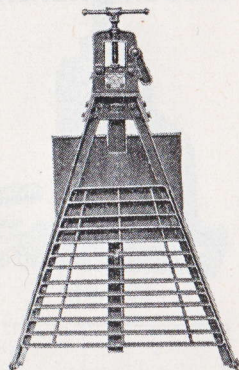
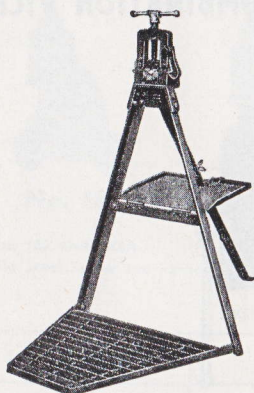

WODEN No. 197A VICE STAND is an improved Tripod Stand of great strength which is easily portable.

The unique feature of this Stand is the metal floor which gives the Stand exceptional stability and affords a firm foothold.

The extending leg enables the Stand, when collapsed, to stand erect.

No.	Fitted with Hinged Tube Vice	To take Tubes	Approx. Weights	Overall	
				Height	Width
1		STAND only :	37 lbs.	36 inches	30 inches
2	No. 180/2	$\frac{1}{8}$ to 2 inches	50 "	46 "	30 "
3	No. 180/3	$\frac{1}{8}$ to 2½ "	54 "	47 "	30 "
4	No. 180/4	$\frac{1}{8}$ to 3½ "	62 "	50 "	30 "

WODEN TOOLS LTD. : WODEN WORKS : WEDNESBURY : ENGLAND



No. 197B

## WODEN PORTABLE AND COLLAPSIBLE VICE STAND

FITTED WITH COMBINATION VICE No. 179

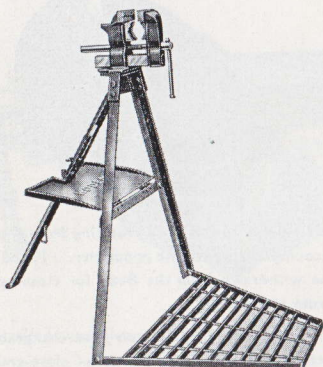

WODEN No. 197B ALL STEEL VICE STAND is an improved Tripod Stand of great strength which is easily portable. The unique feature of this Stand is the metal floor which gives the Stand exceptional stability and affords a firm foothold. The extending leg enables the Stand when collapsed to stand erect.

No.	Stand fitted with	Vice Jaws	To take Tubes	Approx. Weight	Overall Height	Width
197B	No. 179 Vice	4½ inches Offset	⅜ to 2½ ins.	67 lbs.	42 inches	30 inches

WODEN TOOLS LTD. : WODEN WORKS : WEDNESBURY : ENGLAND



No. 186B

# WODEN MECHANIC'S VICE

IMPROVED

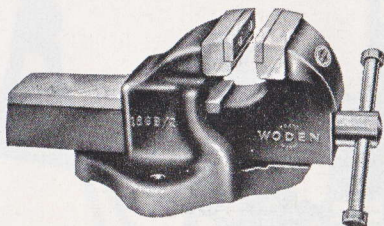

The great strength and rigidity of this Vice resulting from the careful design and accurate Machining accounts for its extreme popularity. Fitted with an unbreakable Nut, the Slide can be withdrawn from the Body for cleaning and oiling without removing the Vice from the Bench.

The hardened Steel Jaw Plates are completely interchangeable, the Screw is of best quality Mild Steel, and the Body and Slide of close-grained Cast Iron.

Number	Width of Jaws	Depth of Jaws	Extent of Opening	Approximate Weights
00	2½ inches	1⅞ inches	2½ inches	5½ lbs.
0	2½ "	1¾ "	2¾ "	8½ "
1	3 "	2 "	3½ "	13½ "
2	3½ "	2½ "	4 "	19 "
3	4 "	2½ "	4¾ "	30 "
4	4½ "	2⅝ "	5½ "	42 "
5	5 "	3 "	6½ "	52 "
6	6 "	3⅝ "	7½ "	66 "
7	7 "	3⅞ "	7½ "	68 "

WODEN TOOLS LTD. : WODEN WORKS : WEDNESBURY : ENGLAND





No. 186B

# WODEN MECHANIC'S VICE

WITH SWIVEL BASE

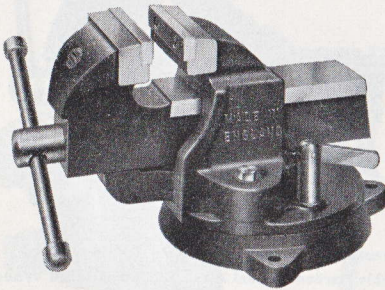

These Vices can be swivelled through a complete circle and locked in any position

Number	Width of Jaws	Depth of Jaws	Extent of Opening	Approximate Weights
00 S	2½ inches	1⅞ inches	2½ inches	10 lbs.
0 S	2½ "	1¾ "	2½ "	13½ "
1 S	3 "	2 "	3½ "	21½ "
2 S	3½ "	2½ "	4 "	26½ "
3 S	4 "	2½ "	4¾ "	43 "
4 S	4½ "	2¾ "	5½ "	57 "
5 S	5 "	3 "	6½ "	68½ "
6 S	6 "	3¾ "	7½ "	87½ "
7 S	7 "	3¾ "	7½ "	91 "

WODEN TOOLS LTD. : WODEN WORKS : WEDNESBURY : ENGLAND



No. 186S

# WODEN UNBREAKABLE VICE

WITH PLAIN SCREW

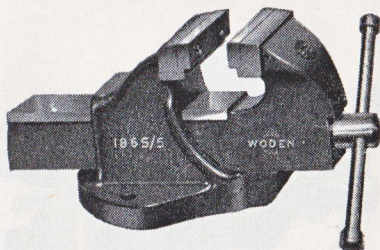

Guaranteed unbreakable Castings. Detachable unbreakable Nut. Steel Screw and handle. Detachable Hardened Steel Jaws. Stove Enamelled Woden Green.

This light, unbreakable Vice is recommended for all general bench work. Where chipping and hammering are involved and the nature of the work does not call for a heavy duty vice, the 186S will show a considerable economy.

## THE WODEN UNBREAKABLE GUARANTEE

The Castings of this Vice are guaranteed unbreakable and will be replaced free of charge at any time in the event of breakage.

Number	Width of Jaws	Depth of Jaws	Opening	Approximate Weights
3	4 inches	2½ inches	4¾ inches	20½ lbs.
5	5 ..	3 ..	6 ..	35 ..
6	6 ..	3½ ..	6½ ..	44 ..

WODEN TOOLS LTD. : WODEN WORKS : WEDNESBURY : ENGLAND



No. 186S

# WODEN UNBREAKABLE VICE

WITH SWIVEL BASE

PLAIN SCREW

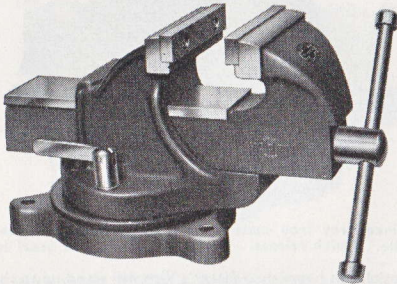

These Vices can be swivelled through a complete circle and locked in any position.

Number	Width of Jaws	Depth of Jaws	Extent of Opening	Approximate Weights
3 S	4 inches	2½ inches	4¾ inches	26 lbs.
5 S	5 "	3 "	6 "	39½ "
6 S	6 "	3½ "	6½ "	52½ "

WODEN TOOLS LTD. : WODEN WORKS : WEDNESBURY : ENGLAND

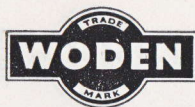

No. 186E

# W O D E N F I T T E R ' S V I C E

WITH INSTANTANEOUS GRIP

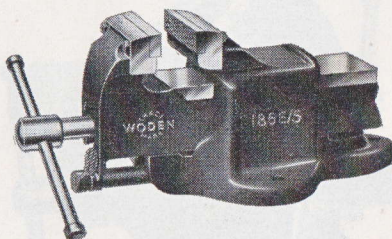

Heavy close-grained grey iron castings. Stove enamelled Woden Blue. Steel Screw and Handle. Quick release. Replaceable hardened Steel Jaws.

Solid and Substantial, this heavy duty Fitter's Vice will stand up to the most arduous conditions of service.

This is the Standard Woden Vice for Industrial Purposes providing great strength and long service, combined with low initial cost.

Number	Width of Jaws	Depth of Jaws	Extent of Opening	Approximate Weights
5	3 $\frac{1}{4}$ inches	2 $\frac{3}{8}$ inches	4 $\frac{1}{2}$ inches	34 lbs.
6	3 $\frac{3}{4}$ "	3 "	5 "	49 "
7	4 $\frac{1}{4}$ "	3 $\frac{3}{8}$ "	6 $\frac{1}{2}$ "	66 "
8	5 $\frac{1}{4}$ "	3 $\frac{3}{4}$ "	7 "	81 "
8A	6 "	4 $\frac{1}{8}$ "	8 "	100 "
9A	7 "	4 $\frac{1}{2}$ "	9 "	130 "
10	8 "	6 "	10 "	204 "

---

WODEN TOOLS LTD. : WODEN WORKS : WEDNESBURY : ENGLAND

---



No. 186E

# WODEN FITTER'S VICE

WITH SWIVEL BASE

INSTANTANEOUS GRIP

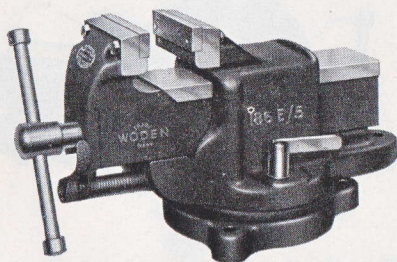

These Vices can be swivelled through a complete circle and locked in any position

Number	Width of Jaws	Depth of Jaws	Extent of Opening	Approximate Weight
5 S	3½ inches	2¾ inches	4½ inches	42½ lbs.
6 S	3¾ ..	3 ..	5 ..	58½ ..
7 S	4½ ..	3¾ ..	6½ ..	79½ ..
8 S	5½ ..	3¾ ..	7 ..	97½ ..
8A S	6 ..	4½ ..	8 ..	116½ ..

WODEN TOOLS LTD. : WODEN WORKS : WEDNESBURY : ENGLAND



No. 190

## WODEN HEAVY-DUTY UNBREAKABLE VICE

WITH INSTANTANEOUS GRIP

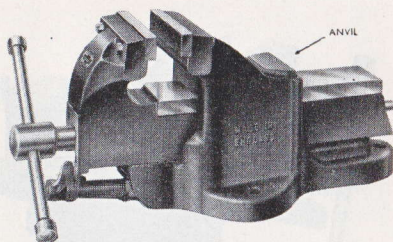

The WODEN 190 is a Vice of exceptional strength, built to withstand continuous hard work. Heavy hammering and chipping can be carried out without fear of failure. Fitters and filers will find the design fulfills all the requirements of a versatile heavy-duty Engineer's Vice.

The Jaw Steels are secured by bolts, ensuring rigidity and giving easy access for maintenance and replacement.

### WODEN UNBREAKABLE GUARANTEE

The Castings of this Vice are guaranteed unbreakable and will be replaced free of charge at any time in the event of breakage.

Number	Width of Jaws	Depth of Jaws	Opening	Approximate Weights
7A	4½ inches	3 inches	5¼ inches	48 lbs.
8	5½ "	3¾ "	6 "	64 "
8A	6 "	4½ "	7 "	90 "
9A	7 "	4½ "	8 "	102 "

WODEN TOOLS LTD. : WODEN WORKS : WEDNESBURY : ENGLAND



No. 190

## WODEN HEAVY-DUTY UNBREAKABLE VICE

WITH SWIVEL BASE

INSTANTANEOUS GRIP

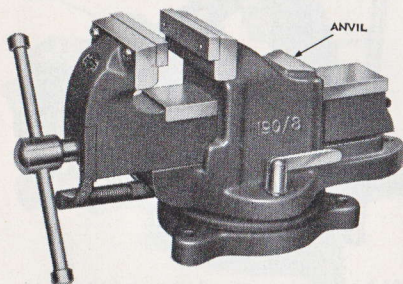

These Vices can be swivelled through a complete circle and locked in any position

Number	Width of Jaws	Depth of Jaws	Extent of Opening	Approximate Weight
7A S	4½ inches	3 inches	5¾ inches	53½ lbs.
8 S	5½ "	3¾ "	6 "	81½ "
8A S	6 "	4½ "	7 "	107½ "

WODEN TOOLS LTD. : WODEN WORKS : WEDNESBURY : ENGLAND



No. 190A

# WODEN HEAVY-DUTY UNBREAKABLE VICE

WITH PLAIN SCREW

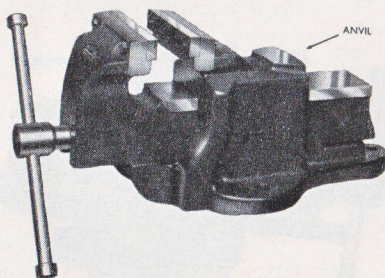

The WODEN 190A is a Vice of exceptional strength, built to withstand continuous hard work. Heavy hammering, chipping and fettling can be carried out without fear of failure. The plain screw action will give trouble-free service in Foundries and Workshops where abrasive dust is abundant.

The Jaw Steels are secured by bolts, ensuring rigidity and giving easy access for maintenance and replacement.

## WODEN UNBREAKABLE GUARANTEE

The Castings of this Vice are guaranteed unbreakable and will be replaced free of charge at any time in the event of breakage.

Number	Width of Jaws	Depth of Jaws	Opening	Approximate Weights
7	4½ inches	3¾ inches	5 inches	46 lbs.
8	5½ ..	3¾ ..	6 ..	61 ..
8A	6 ..	4½	7 ..	84 ..
9A	7 ..	4½ ..	8 ..	100 ..

WODEN TOOLS LTD. : WODEN WORKS : WEDNESBURY : ENGLAND





No. 190A

## WODEN HEAVY-DUTY UNBREAKABLE VICE

WITH SWIVEL BASE

PLAIN SCREW

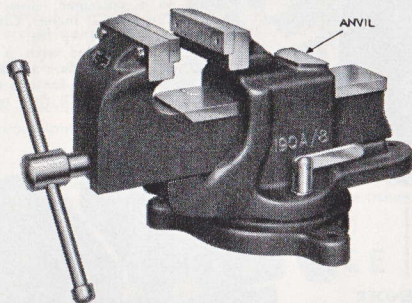

These Vices can be swivelled through a complete circle and locked in any position

Number	Width of Jaws	Depth of Jaws	Extent of Opening	Approximate Weight
7 S	4½ inches	3¾ inches	5 inches	55½ lbs.
8 S	5½ "	3¾ "	6 "	74½ "
8A S	6 "	4½ "	7 "	101 "

---

WODEN TOOLS LTD. : WODEN WORKS : WEDNESBURY : ENGLAND

---



# THE WODEN TITAN VICE

## No. X260

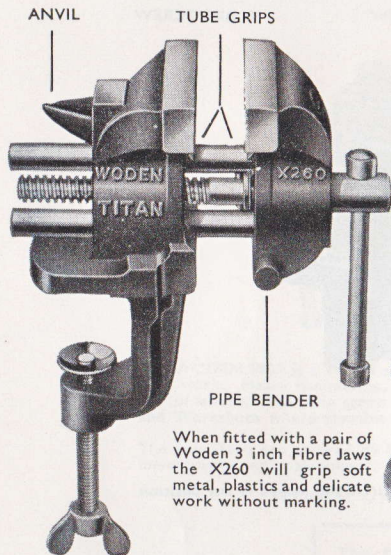

Body and Sliding Jaw in finest quality close-grained grey iron. Guides, Screw and Handle of Steel. Stove enamelled Woden Blue.

Packed in a coloured, illustrated Box. 3" Jaws. Opening 2½ inches. Clamp opening, 1½ inches. Weight 4½ lbs.

The Titan is provided with a Tube Grip, two pipe or rod benders and a useful anvil. It is the perfect Vice for the amateur and model maker and will find many uses in industrial workshops.

When fitted with a pair of Woden 3 inch Fibre Jaws the X260 will grip soft metal, plastics and delicate work without marking.

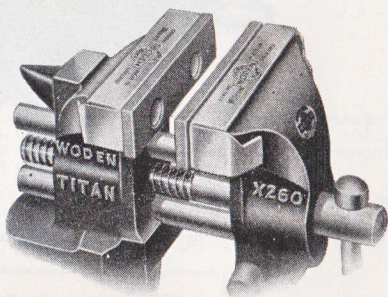

## SWIVEL BASES FOR WODEN VICES

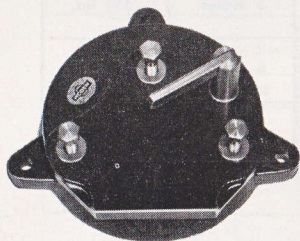

Swivel Bases can be supplied to suit Woden Vices Nos. 186B, 186S, 186E, 190 and 190A.

When ordering a Swivel Base for a Vice previously purchased it is advisable to send the Vice to the Woden Works for fitting. Alternatively the base can be supplied undrilled if the owner has the facilities for drilling and tapping the holes for fitting. Woden Swivel Bases are made of best Cast Iron, with Steel Screws and Nuts supplied.

**PLEASE STATE VICE REF. No. AND SIZE WHEN ORDERING.**

WODEN TOOLS LTD. : WODEN WORKS : WEDNESBURY : ENGLAND



## WODEN DRILLING MACHINE VICE

No. X251

Body and Sliding Jaw precision cast in finest quality close-grained grey iron. Stove enamelled Woden Blue. Steel screw and handle. Smooth jaws. The moving jaw has two horizontal V grips. The fixed jaw has a vertical V slot.

Jaws  $2\frac{1}{2}$  ins. wide,  $1\frac{1}{2}$  ins. deep. Opening  $2\frac{1}{2}$  ins. Weight  $2\frac{1}{2}$  lbs. Each Vice is packed in an illustrated, two-colour box.

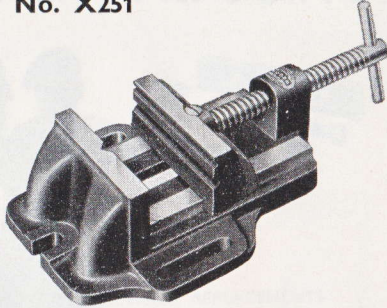

The X251 is designed for use with all popular Electric Drill Stands and Home Workshop Outfits. It has a wide scope in Industry for small repetition work and for the occasional job where a jig is not to hand.

## WODEN MACHINE VICE No. 95

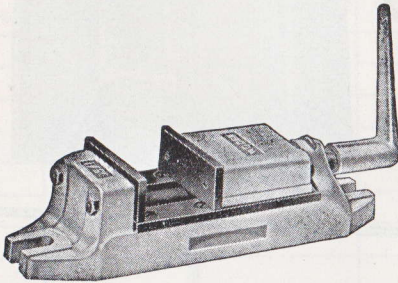

An inexpensive Industrial Machine Vice designed for use on Drillers, Millers and Shapers on jobs which do not demand the use of an expensive precision jig. The main castings are constructed from a special aluminium alloy, heat-treated after casting and virtually unbreakable. The accurately machined screw works in a floating steel nut.

Width of Jaws	Depth of Jaws	Opening	Size of Base	Distance Between Bolt Centres	Approx. Weight
3"	$1\frac{1}{8}$ "	2"	$10\frac{1}{2}$ " x 3"	9"	5 lbs.

WODEN TOOLS LTD. : WODEN WORKS : WEDNESBURY : ENGLAND



# W O D E N F L O O R V I C E

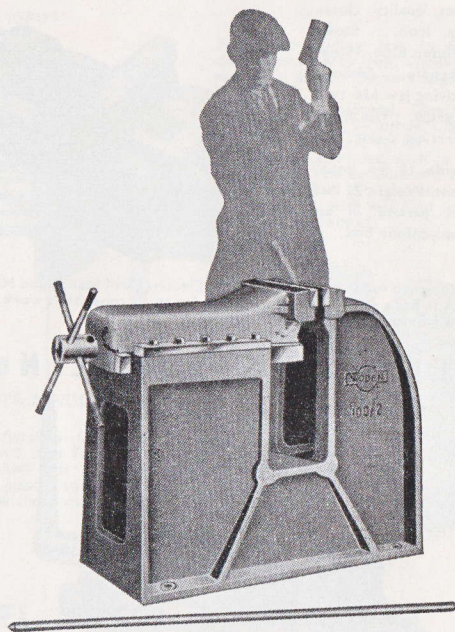

**No. 100/2**

### SPECIFICATION

Width of Jaws	Opening of Jaws	Approximate Weight	Height
12 inches	10 inches	1,000 lbs.	32 inches

**WODEN TOOLS LTD. : WODEN WORKS : WEDNESBURY : ENGLAND**



# WODEN VICE JAW PLATES

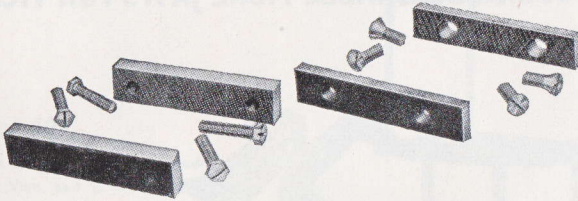

STATE VICE NUMBER WHEN ORDERING REPLACEMENTS

"WODEN" VICE JAW PLATES are made from finest quality Steel, and are carefully hardened and tempered. This composite metal prevents chipping and cracking.

To suit Vice No.	Width of Jaws	To suit Vice No.	Width of Jaws
<b>186B 00</b>	2½ inches	<b>186E 5</b>	3¼ inches
0	2½ "	6	3½ "
1	3 "	7	4½ "
2	3½ "	8	5½ "
3	4 "	8A	6 "
4	4½ "	9A	7 "
5	5 "	10	8 "
6	6 "		
7	7 "		
<hr/>			
<b>186 S 3</b>	4 inches	<b>190 7</b>	4½ inches
5	5 "	<b>&amp; 8</b>	5½ "
6	6 "	<b>190A 8A</b>	6 "
		9A	7 "

WODEN TOOLS LTD. : WODEN WORKS : WEDNESBURY : ENGLAND



## WODEN DETACHABLE FIBRE JAWS FOR VICES

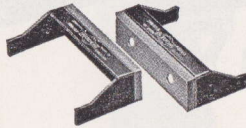

The Steel Lugs (shown straight in illustration above) bend round the Vice Jaws as shown in illustration below) to secure the Grips and fit any Bench Vice.



FINEST VULCANISED FIBRE ON RUSTPROOF PLATED GRIPS

No Vice is complete without a pair of these Fibre Jaws. Slipped on and off instantly for handling delicate work.

Made to fit Vices with width of Jaws :—

2½" 2¾" 3" 3¼" 3½" 3¾" 4" 4¼" 4½" 5" 5½" 6" 7"

WODEN TOOLS LTD. : WODEN WORKS : WEDNESBURY : ENGLAND



## WODEN PORTABLE VICE STANDS

### No. 195

This Stand is made in suitable strength for any Vice, and is for use in confined spaces among Machines, Lathes, etc.

Top of Table .... 18 × 19 inches  
Height of Table .... 30 inches  
Weight .... 3 qrs. 14 lbs.

A Rack for holding Eight Files forming a Tray for holding small articles is fitted. The Base serves as a Shelf.

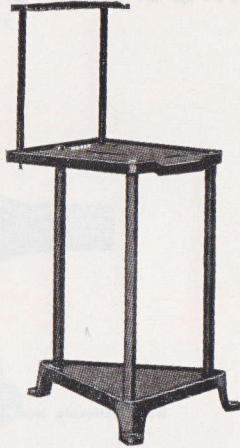

### No. 196

This Stand is especially suitable for a corner position. It is popular, fitted with a No. 186B/2 Parallel Mechanics' Vice with 3½ in. Jaws. The Stand, however, is very strong and is quite suitable for a much larger Vice if required.

Top of Table .... 17½ × 18½ inches  
Height of Table .... 30 inches  
Approximate Weight .... 3 qrs. 0 lbs.



No. 191

# WODEN LATHE CARRIERS

IMPROVED

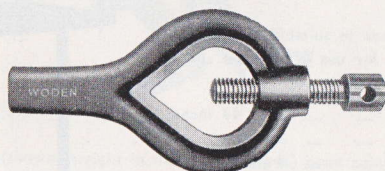

Best Malleable Iron Body, Steel Screw with hardened point.

Inside size ..	$\frac{1}{2}$	$\frac{3}{4}$	1	$1\frac{1}{2}$	$1\frac{1}{2}$ ins.
Weight .. ..	4 ozs.	6 ozs.	9 ozs.	13 ozs.	$1\frac{1}{2}$ lbs.
Inside size ..	$1\frac{1}{2}$	2	$2\frac{1}{2}$	3	4 ins.
Weight .. ..	2 lbs.	$2\frac{3}{4}$ lbs.	4 lbs.	6 lbs.	$7\frac{1}{2}$ lbs.

WODEN TOOLS LTD. : WODEN WORKS : WEDNESBURY : ENGLAND





No. 239A

# WODEN LIFTING JACKS

SHORT LIFT JACK

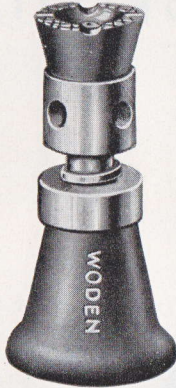

Cast Iron Body and Head, fitted with Mild Steel Screw.

No.	To Lift	Height when Down	Range of Lift	Approximate Weight
1	2 tons	7 inches	2½ inches	8½ lbs.
1A	3 ..	7½ ..	2½ ..	9½ ..
2	4 ..	8 ..	2½ ..	12 ..
2A	5 ..	8½ ..	3 ..	15 ..
3	6 ..	9 ..	3½ ..	16 ..
3A	8 ..	10 ..	3½ ..	20½ ..
4	10 ..	10 ..	3½ ..	25½ ..

WODEN TOOLS LTD. : WODEN WORKS : WEDNESBURY : ENGLAND



Nos. 240 & 240A

# WODEN LIFTING JACK



Circular Head.  
No. 240



Oval Head.  
No. 240A

Cast Iron Body and Head, fitted with Mild Steel Screw.  
Round Steel Lever Rods supplied, if specified.

No.	To Lift	Height when Down	Range of Lift	Approximate Weight
0	1½ tons	12 inches	7 inches	10 lbs.
1	2 "	14 "	8½ "	12 lbs.
2	3 "	14 "	9 "	17 lbs.
3	4 "	18 "	11 "	23½ lbs.
4	5 "	21 "	14 "	33 lbs.
5	6 "	24 "	15½ "	40 lbs.
6	8 "	24 "	15 "	46 lbs.
7	10 "	24 "	14½ "	51 lbs.

WODEN TOOLS LTD. : WODEN WORKS : WEDNESBURY : ENGLAND



Nos. 229 & 229A

# WODEN LIFTING JACKS



**Round Head  
No. 229**

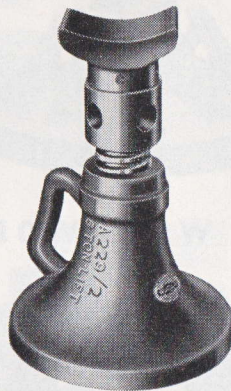

**Crutch Head  
No. 229A**

Cast Iron Body, Mild Steel Screw fitted with Cast Iron Cap.  
Round Steel Lever Rods supplied, if specified.

No.	To lift	Height when down		Diameter of Base	Diameter of Screw	Range of Lift	Approx. Weight
		229	229A				
1	Up to 3 tons	10"	10 $\frac{3}{8}$ "	7 inches	1 $\frac{3}{4}$ inches	3 $\frac{3}{4}$ inches	19 lbs.
2	4 to 6 tons	10"	11 $\frac{1}{4}$ "	8 $\frac{1}{2}$ "	2 "	3 $\frac{1}{2}$ "	29 lbs.

WODEN TOOLS LTD. : WODEN WORKS : WEDNESBURY : ENGLAND

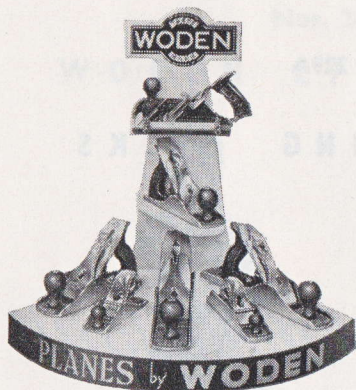

## WODEN PLANES

### THE WP7.

This attractive Display Unit, in timber and plywood, cellulosed in four colours, effectively sells Woden Planes.

It comes packed in a fibrite container together with one each W78; W4; W5; W4½; W5½; W110; W130.

The Planes only are invoiced. Stands are free. See page 5 for details of the WP9.

## WOODWORKERS' VICES

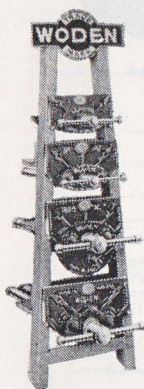

WW4

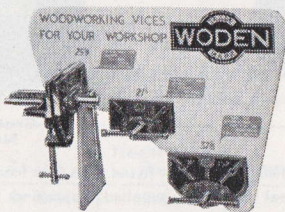

WW3

These stands provide an opportunity to develop sales by displaying the popular range of Woden Woodworkers' Vices. The Stands are free—only the Vices are invoiced.

WW3 displays one each No. 194, No. 194A, No. 192.

WW4 displays one each No. 194, No. 192, No. 189B/1, No. 189/1A.

WW6 displays one each No. 194, No. 192, No. 189B/1, No. 189/1A, No. 189B/2, No. 189B/3.

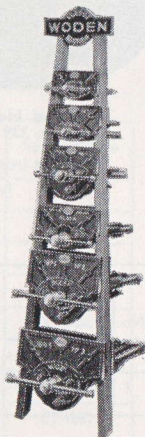

WW6

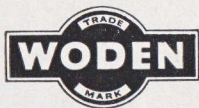

## WODEN DISPLAY STANDS ENGINEERS' AND FITTERS' VICES

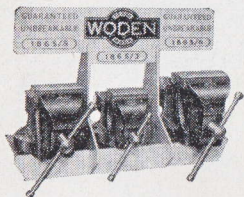

VSS3

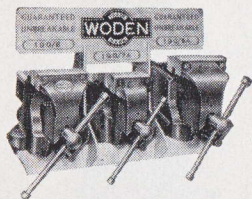

VSU3

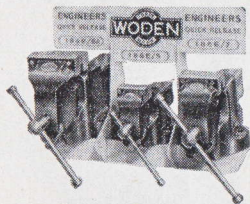

VSE3

These compact stands are constructed of four interlocking plywood sections, cellulosed in five colours. They can be dispatched through the post and are easily assembled from the instructions supplied with each stand.

They are free of charge on request, when covered with an order for the accompanying Vices.

VSS3	....	displays one each	186S No. 3:	No. 5:	No. 6.
VSU3	....	.. ..	190 No. 7A:	No. 8:	No. 8A.
VSE3	....	.. ..	186E No. 5:	No. 7:	No. 8A.



# WODEN DISPLAY STANDS

## MECHANICS' VICES No. 186B

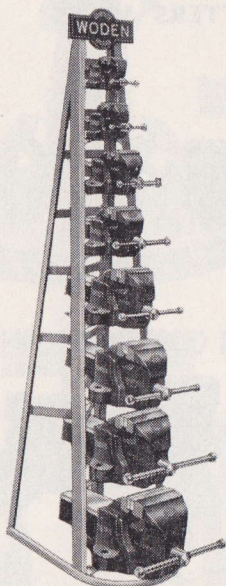

**FS.8. FLOOR STAND**

Height .... 58"  
 Floor Space .... 20" x 16"  
 Weight .... 28½ lbs.

Folds Flat for Export.

Displays one of each size 186B Vices  
 No. 00 to No. 6 inclusive.

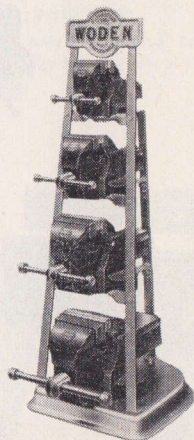

**CS.4. COUNTER STAND**

Height .... 27½"  
 Counter Space .... 10" x 10"  
 Weight .... 6½ lbs.

Displays one of each size 186B Vices  
 No. 00 to No. 2 inclusive.

These stands are supplied free to customers who regularly stock and sell WODEN VICES. Constructed in Steel, finished Silver.

